

HS-100 Series Vibration Sensor

M12 Connector, 100mV/g Industrial Accelerometer



Typical Applications

- Proven use in vibration monitoring for offline applications using commercially available data collectors and online monitoring systems in the fields of Building Services, Civil Engineering, Paper and Pulp, Mining, Metals Manufacture, Utilities, Automotive, Water and Waste Treatment, Pharmaceutical, Aerospace, Wind Power, etc.
- **Protecting...**
Fans, Motors, Pumps, Compressors, Centrifuges, Conveyers, Air Handlers, Gearboxes, Rolls, Dryers, Presses, Cooling, HVAC, Spindles, Machine Tooling, Process Equipment and many more.

Technical Performance

Mounted Base Resonance	22 kHz (nominal)
Sensitivity	100 mV/g $\pm 10\%$ Nominal 80 Hz at 22 °C
Frequency Response	2 Hz to 10 kHz $\pm 5\%$ 0.8 Hz to 15 kHz ± 3 dB
Isolation	Base isolated
Measurement Range	± 80 g
Transverse Sensitivity	Less than 5%

Electrical

Electrical Noise	0.1 mg max
Current Range	0.5 mA to 8 mA
Bias Voltage	10 - 12 Volts DC
Settling Time	2 seconds
Output Impedance	200 Ohms max.
Case Isolation	$>10^8$ Ohms at 500 Volts

Environmental

Operating Temperature Range	-25 to 80 °C
Sealing	IP67
Maximum Shock	5000 g
Emissions	EN61000-6-4:2001
Immunity	EN61000-6-2:1999

Mechanical

Case Material	Stainless Steel
Sensing Element/Construction	PZT/Compression
Mounting Torque	8 Nm
Weight	110 gms (nom)
Maximum Cable length	1000 metres
Mounting Thread	M8 x 1.25mm Male
Options	Integral cable, filters, temperature output, various connector assemblies, other sensitivities

PRODUCT DATA

HS-100 Series Vibration Sensor

Dimensions

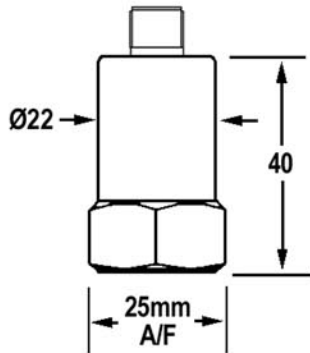

Pin 1 - No connection
 Pin 2 - +18 to 30 V (white)
 Pin 3 - No connection
 Pin 4 - 0V (black)

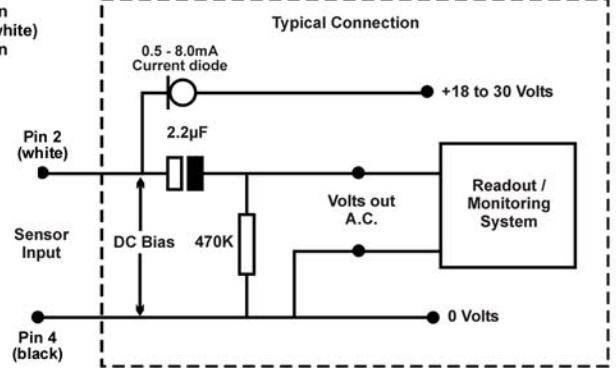

Frequency Response

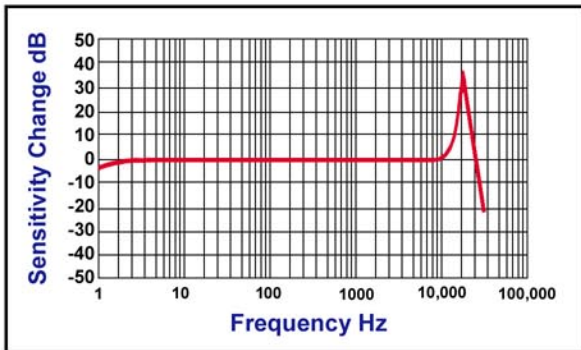

Mounting of sensor to achieve good repeatable readings. Vibration sensor should be firmly fixed to a flat surface (spot face surface may be needed to be produced and cable anchored to sensor body.)

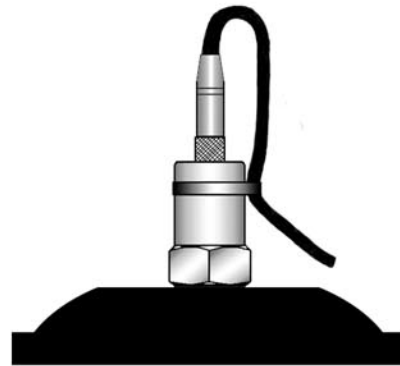

How to order

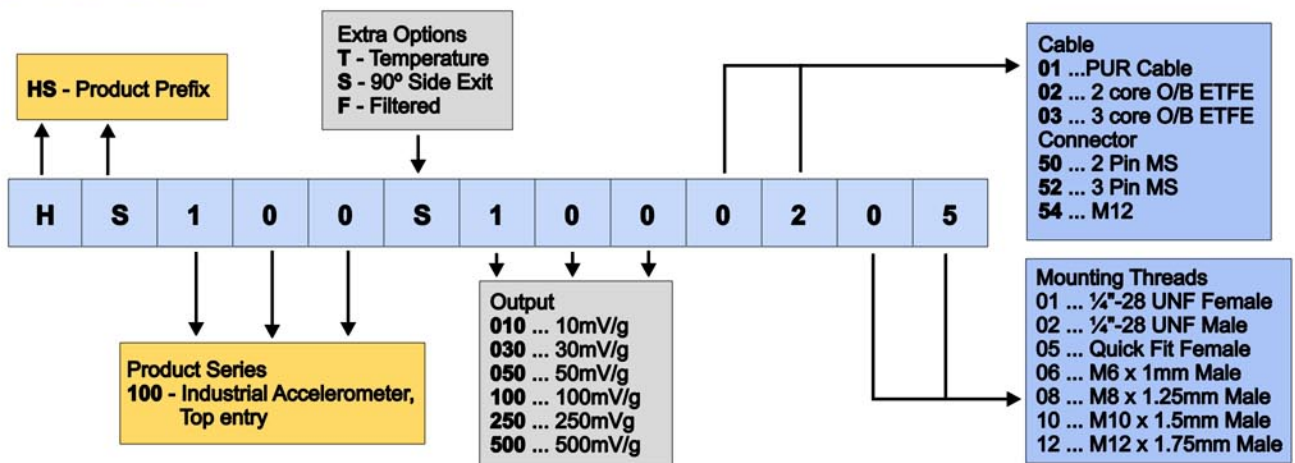

Please contact our Sales Office for information on sensor accessories (mounting studs, etc) and multichannel switch boxes.