

HS-420 Series Vibration Sensor

4-20mA Velocity Transducer for PLC Interface



Typical Applications

- Low cost online means of monitoring with the capability of interfacing direct into PLC, BMS or any 4-20mA input module.
Proven use in vibration monitoring for offline applications using commercially available data collectors.
- **Protecting...**
Fans, Motors, Pumps, Compressors, Centrifuges, Conveyers, Air Handlers, Gearboxes, Rolls, Dryers, Presses, Cooling, HVAC, Spindles, Machine Tooling, Process Equipment and many more.

Technical Performance

Mounted Base Resonance	5 kHz min.
Velocity Ranges	0-10 to 0-100 mm/sec RMS (5 ranges)
Frequency Response	10 Hz to 1 kHz $\pm 5\%$ - ISO10816
Isolation	Base isolated
Measurement Range	50 g peak
Transverse Sensitivity	Less than 5%

Electrical

Output Current	4-20 mA DC proportional to RMS velocity (mm/s)
Supply Voltage	15 - 30 Volts DC (for 4-20 mA)
Settling Time	2 seconds
Output Impedance	Loop Resistance 600 Ohms max. at 24 Volts
Case Isolation	$>10^8$ Ohms at 500 Volts

Environmental

Operating Temperature Range	-25 to 90 °C
Sealing	IP67
Maximum Shock	5000 g
Emissions	EN61000-6-4:2001
Immunity	EN61000-6-2:1999

Mechanical

Case Material	Stainless Steel
Sensing Element/Construction	PZT/Compression
Mounting Torque	8 Nm
Weight	140 gms (nom)
Mating connector	HS-AA004
Mounting Threads	See 'How to order' table
Options	Ranges, filters, mating cable, assemblies, high temperatures

PRODUCT DATA

HS-420 Series Vibration Sensor

Dimensions

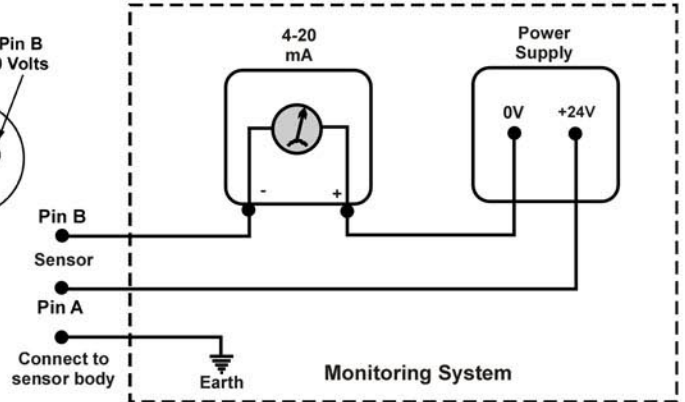
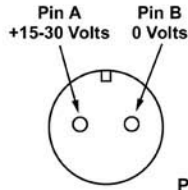
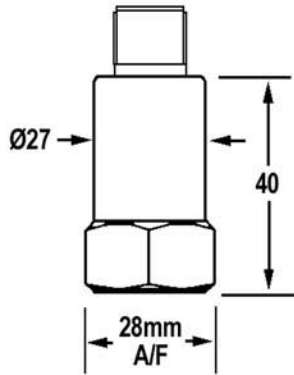

Frequency Response

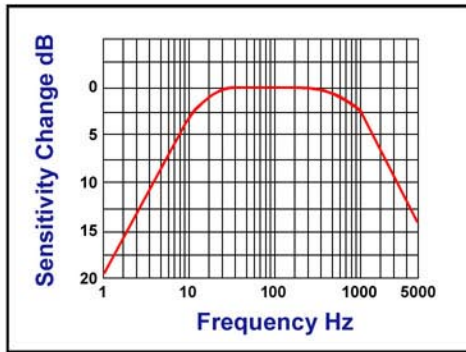

Mounting of sensor to achieve good repeatable readings. Vibration sensor should be firmly fixed to a flat surface (spot face surface may be needed to be produced and cable anchored to sensor body.)

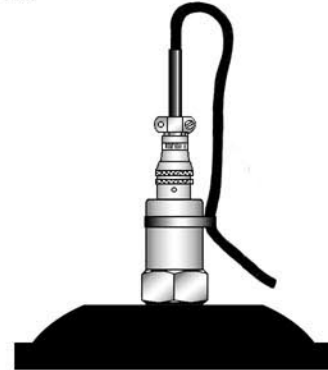

How to order

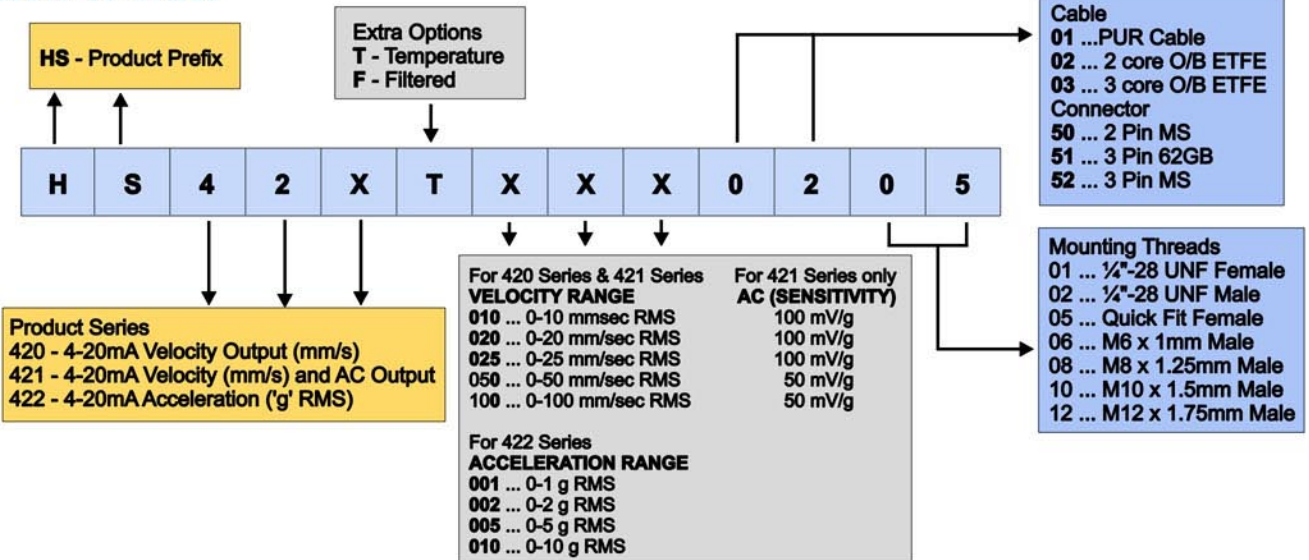

Please contact our Sales Office for information on sensor accessories (mounting studs, etc) and multichannel switch boxes.